



Hodge Clemco

MJC Cartridge Filter Units Installation

Owner's Manual

Date of Issue: 20.07.04 TS.SM 536.2

Hodge Clemco Ltd
Orgreave Drive
Sheffield
S13 9NR
Tel: 0114 254 8811
Fax: 0114 254 0250
Email: sales@hodgeclemco.co.uk
www.hodgeclemco.co.uk

Date of Issue: 20.07.04 TS.SM 536.2

INSTALLATION INSTRUCTIONS for MJC filter and accessories

Contents.

Introduction	page 05.01	Mounting on foundation	page 05.03
The main components of the filter	page 05.01	Duct connections	page 05.03
Shipment	page 05.01	Electrical connection	page 05.05
Assembly of the filter	page 05.02	Comp.-air connection	page 05.05
Filter location	page 05.03	Operation out of sight	page 05.05
		Start-up	page 05.06

Introduction.

Installation and start-up of the MJC filter is only to be performed by experienced staff, as errors may cause damage or reduce the life of the filter considerably.

These instructions and the Safety Guidance Notes should be read carefully prior to INSTALLATION and start-up

Main components of the filter:

(Fig. 1).

1. Filter case with filter cartridges
2. Filter hopper
3. Top access lid.
4. Compressed air tank
5. Diaphragm valve for cartridge cleaning
6. Electrical controls
7. Fan (optional)
8. Dirty air inlet (on all larger units at rear or side at high level).
9. Cleaned air outlet from fan.
10. Silencer for fan (optional, not shown)
11. Quick release dust bin (optional)
12. Bin isolation damper (optional)

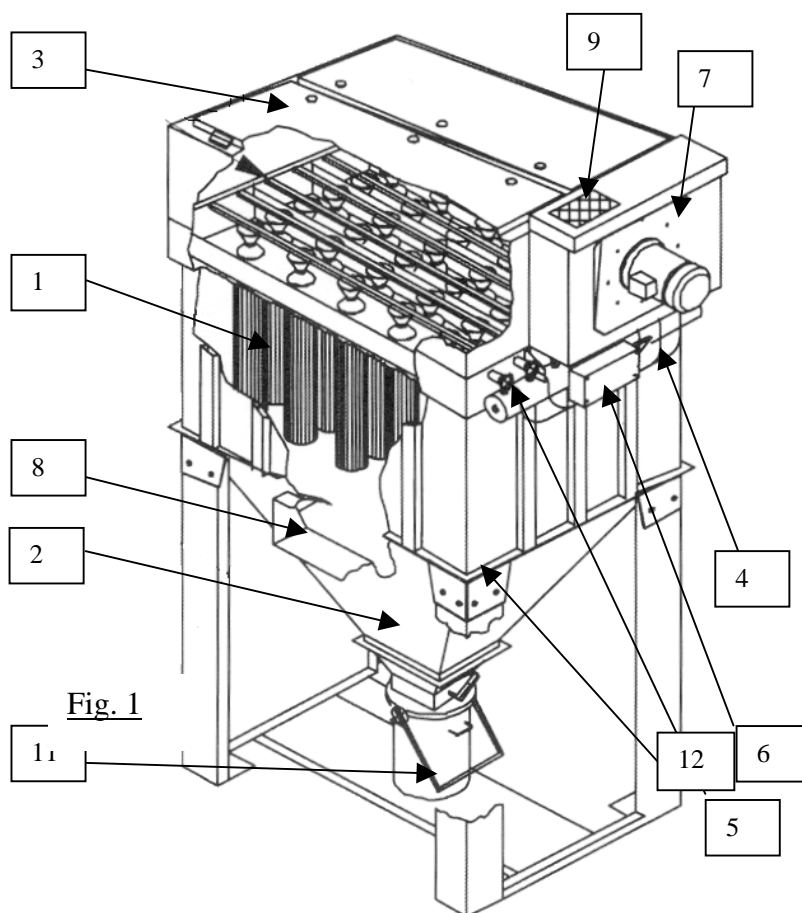

Fig. 1

Shipment.

Normally the filter is dispatched with the hopper separate, but small units may be despatched complete. They are normally shrink-wrapped

Filter assembly.

The unit may be delivered completely assembled. Larger units may be delivered in sections, in which case the procedure will be as below.

Step 1

The hopper is lifted into position (using a maximum slinging angle of 30 degrees from the vertical) onto a prepared base and bolted to the ground.

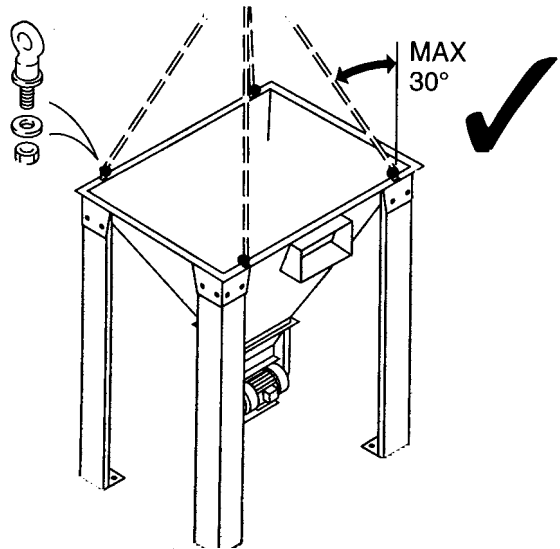

Fig. 2

Step 2

If supplied separated, the filter top section and dirty air case should be bolted together after applying sealant to the flange. The lifting should be via the eyes on top of each corner and a with maximum slinging angle from vertical of 30 degrees.

The filter, including clean air section and dirty air section, is placed onto the hopper, after sealant has been applied to the hopper top flange.

The two parts are bolted together.

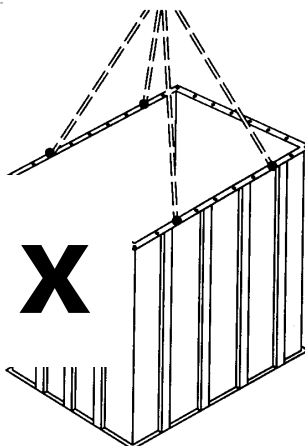
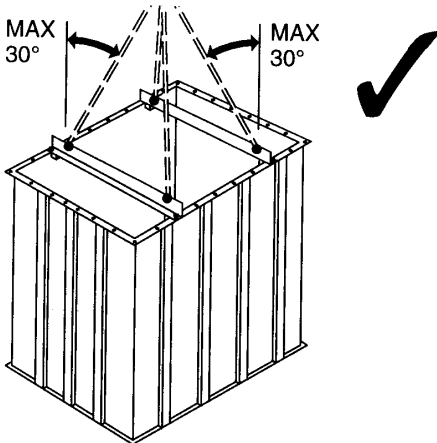
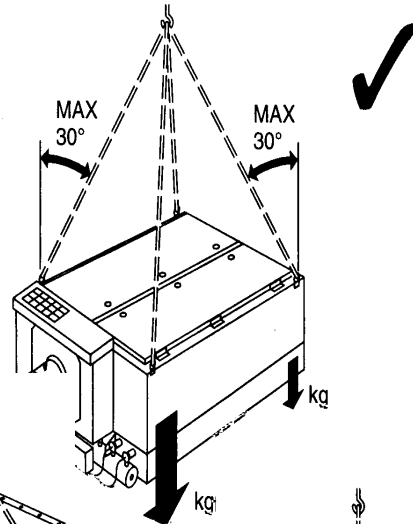

The motor will be fitted with mounting plate and impeller before lifting.



Fig. 3

Filter location.

The filter should be positioned according to the installation drawing, but should always allow space for servicing access to the front or top access doors for cartridge removal and access to the reverse jet controls. Particular care should be exercised when positioning a unit fitted with an explosion relief panel so that it complies with local regulations. In case of doubt please consult our technical department

Mounting on foundation.

When lifting the filter unit a crane should be used. The lifting should be performed using the lifting eyes on top of each corner with a maximum slinging angle of 30 degrees from the vertical. When the filter has been positioned the base plates of the filter legs should be bolted to the foundation if there is a possibility of wind loads, or if the unit is top heavy.

Concrete foundations are the preferred option for outdoor sites. Small filters sited indoors may stand on any horizontal hard surface. If the filter is top-heavy, always bolt to foundations.

If the filter is to be placed above ground level or on a roof it may be mounted on a steel structure. Steel structures for large filters and for roof mounted filters shall be designed in accordance with local or national standards, taking into account dead and imposed loads, corrosion allowance etc.

Ductwork connections.

When the filter has been mounted on the foundation the duct connections can be made. For filters with dustbins equipped with bin balance assemblies, the connection hose to the clean air section of the filter must be fitted and plastic liners must always be used in the dustbins.

Duct connections within work places must be performed in accordance with current local regulations. In some applications with explosive dust types, explosion vents or non-return dampers in the inlet and outlet ducts may be required.

WARNING

In order to prevent unintentional access to rotating parts all duct joints up to 1 meter from rotating elements (e.g. screw conveyor, rotary valve) must have flanged joints or similar so that access is only possible by using tools.

When the installation has been completed it should be checked that all filter cartridges have been fitted correctly and that the ducting joints have been sealed.

Inspection panels or access doors in filters or adjoining components must be retained so that tools are required to open them. On or immediately beside the door relevant warning signs should be applied. The warning sign "Rotating parts" must be applied where relevant. Catches, handles etc. are not allowed!!

External emergency stop switches should generally be placed within sight of the filter unit and must comply with national electrical regulations.

For plants for inflammable and explosive dust the duct system must be made from conducting material so that formation of static electricity is prevented. For non-conducting short connection elements e.g. flexible connections an earth wire (min. 2.5 mm²) should be fitted to the outside of the connection element between the duct ends.

If no suitable earth bonding connection is available on site, it may be possible to use an earth rod to ground accumulated static electricity. A typical arrangement is shown below in fig. 4 for guidance only.

- A: Typical hopper leg
- B: Foundation
- C: Ground
- D: Connection M10 screw + cable eye
- E: Cable connection. Size 6-25 mm²; however, not smaller than 50% of the biggest conductor connected to the plant and not bigger than 25 mm².
- F: Terminal box for earth rod
- G: Earth rod
 - 16 mm² min. with corrosion jacket
 - 25 mm² min. for copper without jacket
 - 50 mm² min. for hot galvanised steel

D, E, F and G should be compatible materials due to corrosion conditions.

If in doubt about grounding conditions, please consult your local electricity supply company

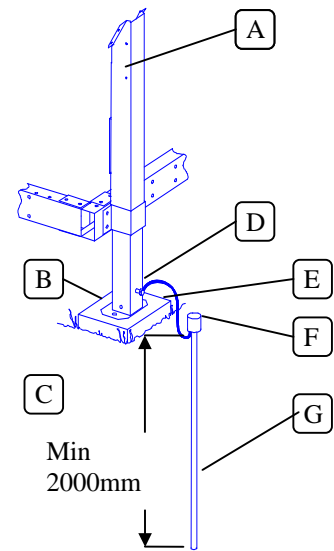

Figure 4 shows typical arrangement

Electrical connections

MJC filters are normally fitted with a sequence timer for the reverse jet cleaning, of the type NF-8H/250 or later NF-8HD/250. This also has plastic hose connections (+ to P1, - to P2) to measure differential pressure.

For filters supplied without a controller, an electrical controller that is an exact approved equivalent must be used. If this is not the case our guarantee on the product will be void.

Electrical connection of NF-8HD/250 should be performed by skilled electricians and comply with national electrical regulations. External connections to the controller are shown in the relevant circuit diagram. See separate manual for the controller NF-8HD/250.

External emergency stop switches will generally be placed within 50 meters of the filter and in any case must comply with national electrical regulations.

Connections to the fan motor, timers etc. should be made in accordance with their particular instructions. Erecting instructions for components delivered by can be ordered in writing from.

The electrical installation must conform to national electrical regulations.

Compressed air connection.

The compressed air installation should include a water and oil separator and a pressure-reducing valve. At a supply pressure over 8 barg a safety valve should be inserted between the pressure-reduction and pressure tank.

- Fig. 5

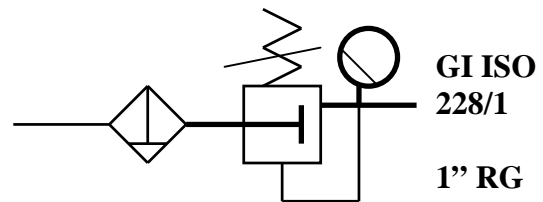

Note that the operating pressure for MJC Type 1 & 2 units is 6.2barg. and for Type 44 & 66 units it is 5.5 barg.

Pipe layout, valves etc. between compressor and the pressure tank of the filter should be made of at least 1/2 " pipes. Refilling of the pressure tank after a cleaning pulse should take no longer than about two seconds.

If the filter is normally out of sight of the operators....

If the filter unit is part of a plant, where the filter is normally out of sight and where a defective filter function may lead to a dangerous situation, the operation of the filter must be monitored by means of a differential pressure indicator located in a prominent position, or an alarm switch, so that any malfunction can be notified immediately.

Initial start.

Prior to start-up the Safety Guidance Notes should be read carefully.

Prior to start-up of the filter, the duct system etc. should be checked carefully and *any* foreign bodies are to be removed.

Defects, if any, should be repaired prior to start up.

1. Start the compressor/open the compressed air supply.
2. Check that the pressure in the pressure tank of the filter is 6.2 barg. for types 1 & 2; 5,5 barg. for types 44 & 66.
3. Check that dustbins are not overfilled. Normally dust must not be stored in the containers. They should be emptied after the start of each operation period, when the automatic after-cleaning period, if applicable, is completed and the dust has settled.
4. Start the fan and check the direction of rotation.
5. Check that the reverse jet cleaning starts when the fan starts. (If a controller with a clean on demand function, such as the NF-8HD/250, is fitted, set the DeltaP switch to OFF to enable the cleaning to be run in test mode. Re-set the switch to ON to enable the cleaning function to operate on demand)
6. Check that all the cleaning valves operate by listening to each in turn.
7. If an NF-8H/250 or NF-8HD/250 electrical controller is fitted, re-set the DeltaP switch to ON to enable the cleaning function to operate on demand.
8. Measure the running current of fan and any other motors and compare these values with the motor full load currents. If a motor current is too high, stop the motor immediately and then refer to the fault-finding section in the Operating Instructions. If still in doubt, please refer to the Technical Office.
9. For filters with regulating dampers on the cleaned air side, these are mounted at the fan or silencer outlet and adjusted by means of a quadrant lever. These should be used to regulate the airflow when commissioning.

If in doubt, please contact our technical department on 0114 254 0600.